

SOLDER SUFFIX	CUSTOMER TERMINAL	RoHS	LEAD(Pb)-FREE
LF3	Sn100%	Yes	Yes

ELECTRICAL SPECIFICATIONS @ 25°C unless otherwise noted:

- INDUCTANCE: 350nH min., 100kHz, 100mV, 6mADC, J1-J2; J3-J6, 1p.
- DIELECTRIC RATING: 1500Vrms for 1 minute between P1-J1(the P1+P3).
- TURNS RATIO/POLARITY: (P1-P2):(J1-J2) = 1:1, ±2%.
(P3-P6):(J3-J6) = 1:1, ±2%.
- INSERTION LOSS: -1.0dB max., 1MHz - 65MHz.
- RETURN LOSS: -18dB typ., 1M - 30MHz.
-16dB typ., 30M - 45MHz.
-14dB typ., 45M - 60MHz.
-12dB typ., 60M - 80MHz.
- CROSSTALK: -33dB typ., 1MHz - 100MHz.
- COMMON MODE REJECTION: -35dB typ., 1MHz - 100MHz.
- OPERATING TEMPERATURE RANGE: 0°C to +70°C.

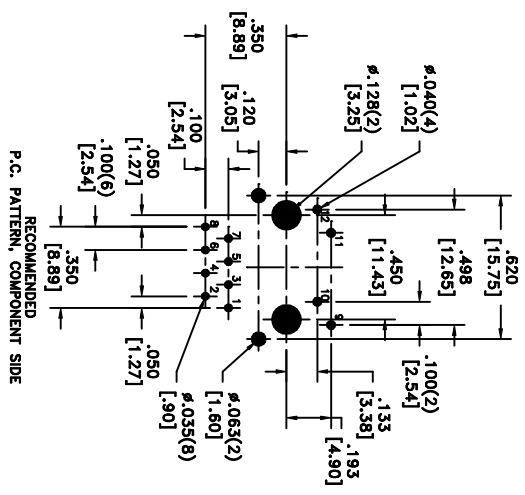
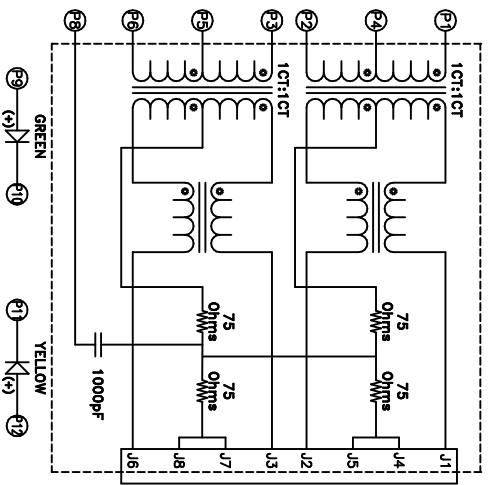
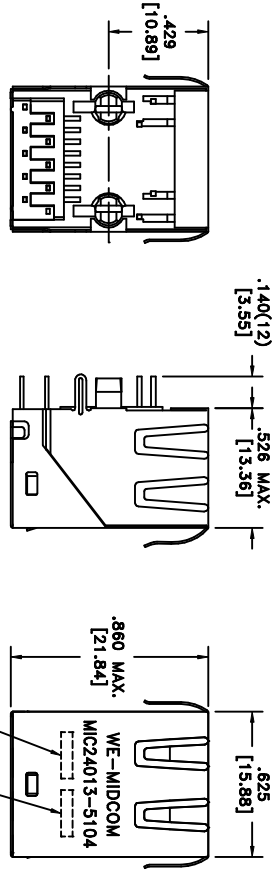
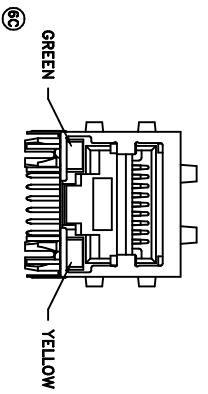

RECOMMENDED
P.C. PATTERN, COMPONENT SIDE