

PART MUST INSERT FULLY TO SURFACE A IN RECOMMENDED GRID
 .016 SQ.(6)
 [.41]

* DIMENSION MAY BE EXCEEDED WITH SOLDER ONLY

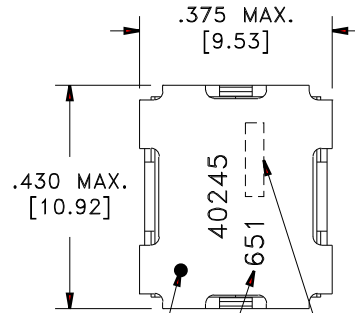
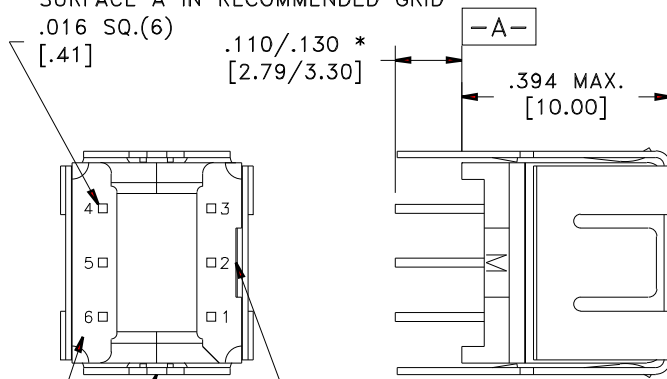

DOT LOCATES TERM. #1

NOTCH LOCATES TERM. #1-3 SIDE

EIA CODE

LOT CODE & DATE CODE

.012 x .036 REF.(2)
 [.30 x .91]

TERM. NO.'s FOR REF. ONLY

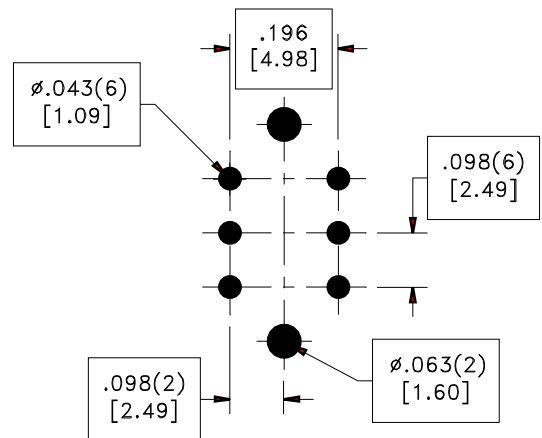
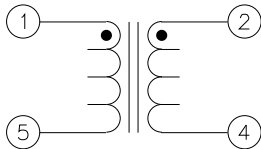

RECOMMENDED
 P.C. PATTERN, COMPONENT SIDE

ELECTRICAL SPECIFICATIONS @ 25°C unless otherwise noted:

- D.C. RESISTANCE (@20°C): 1-5, 1.10 ohms ±10%.
 2-4, 1.10 ohms ±10%.
- DIELECTRIC RATING: 1250VAC for 1 second between 1-4.
- INDUCTANCE: 266.4uH ±6%, 10kHz, 100mVAC, 1-5, Ls.
- URNS RATIO: (1-5):(2-4) = 1:1, ±1%.

DETAILS SUBJECT TO CHANGE

Midcom, Inc.

Watertown, SD USA
 Toll Free: 800-643-2661
 Fax: 605-886-4486

This drawing is dual dimensioned.
 Dimensions in brackets are in millimeters.

Unless otherwise specified:
 Tolerances: Fractions: ±1/64
 Angles: ±1° Decimals: ±.005(.127mm)
 DRAWING TITLE

INDUCTOR

REVISIONS: SEE SHEET 1

Midcom

DRAWING NO.

40245

REV.

6A

SCALE ---

SHEET 2 OF 5

DWG.# 40245